

FLUIDS

1. An incompressible liquid is kept in a container having a weightless piston with a hole. A capillary tube of inner radius 0.1 mm is dipped vertically into the liquid through the airtight piston hole, as shown in the figure. The air in the container is isothermally compressed from its original volume  $V_0$  to  $\frac{100}{101}V_0$  with the movable piston. Considering air as an ideal gas, the height ( $h$ ) of the liquid column in the capillary above the liquid level in cm is \_\_\_\_\_.

[Given: Surface tension of the liquid is  $0.075 \text{ Nm}^{-1}$ , atmospheric pressure is  $10^5 \text{ N m}^{-2}$ , acceleration due to gravity ( $g$ ) is  $10 \text{ m s}^{-2}$ , density of the liquid is  $10^3 \text{ kg m}^{-3}$  and contact angle of capillary surface with the liquid is zero] [JEE(Advanced) 2023]

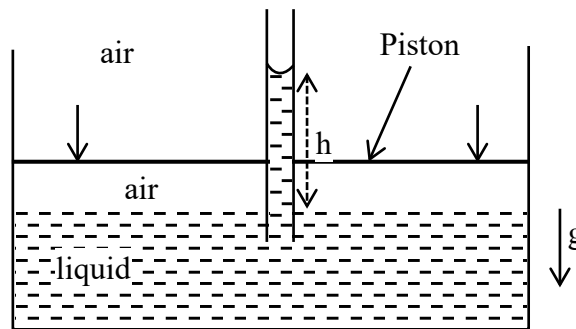

Paragraph for Question No. 2

A cylindrical furnace has height ( $H$ ) and diameter ( $D$ ) both 1 m. It is maintained at temperature 360 K. The air gets heated inside the furnace at constant pressure  $P_a$  and its temperature becomes  $T = 360 \text{ K}$ . The hot air with density  $\rho$  rises up a vertical chimney of diameter  $d = 0.1 \text{ m}$  and height  $h = 9 \text{ m}$  above the furnace and exits the chimney (see the figure). As a result, atmospheric air of density  $\rho_a = 1.2 \text{ kg m}^{-3}$ , pressure  $P_a$  and temperature  $T_a = 300 \text{ K}$  enters the furnace. Assume air as an ideal gas, neglect the variations in  $\rho$  and  $T$  inside the chimney and the furnace. Also ignore the viscous effects.

[Given: The acceleration due to gravity  $g = 10 \text{ ms}^{-2}$  and  $\pi = 3.14$ ] [JEE(Advanced) 2023]

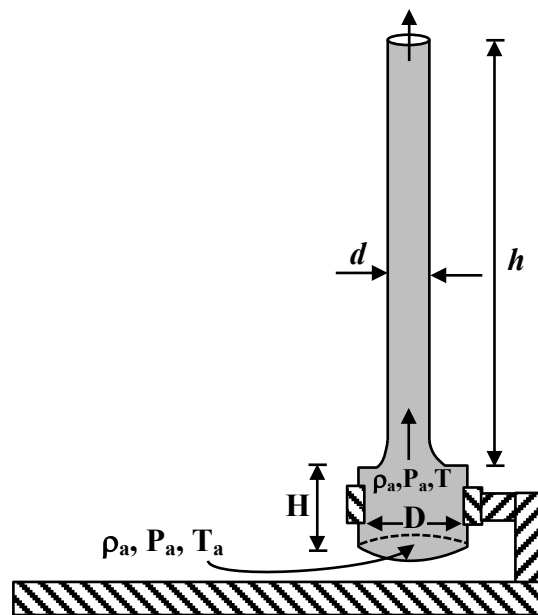

2. Considering the air flow to be streamline, the steady mass flow rate of air exiting the chimney is \_\_\_\_\_  $\text{gm s}^{-1}$ .

Paragraph for Question No. 3

A cylindrical furnace has height ( $H$ ) and diameter ( $D$ ) both 1 m. It is maintained at temperature 360 K. The air gets heated inside the furnace at constant pressure  $P_a$  and its temperature becomes  $T = 360$  K. The hot air with density  $\rho$  rises up a vertical chimney of diameter  $d = 0.1$  m and height  $h = 9$  m above the furnace and exits the chimney (see the figure). As a result, atmospheric air of density  $\rho_a = 1.2 \text{ kg m}^{-3}$ , pressure  $P_a$  and temperature  $T_a = 300$  K enters the furnace. Assume air as an ideal gas, neglect the variations in  $\rho$  and  $T$  inside the chimney and the furnace. Also ignore the viscous effects.

[Given: The acceleration due to gravity  $g = 10 \text{ ms}^{-2}$  and  $\pi = 3.14$ ]

[JEE(Advanced) 2023]

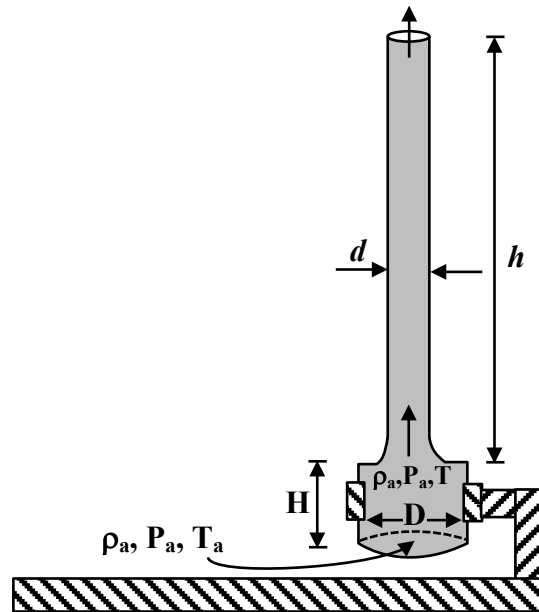

3. When the chimney is closed using a cap at the top, a pressure difference  $\Delta P$  develops between the top and the bottom surfaces of the cap. If the changes in the temperature and density of the hot air, due to the stoppage of air flow, are negligible then the value of  $\Delta P$  is \_\_\_\_\_  $\text{Nm}^{-2}$ .
4. An ideal gas of density  $\rho = 0.2 \text{ kg m}^{-3}$  enters a chimney of height  $h$  at the rate of  $\alpha = 0.8 \text{ kg s}^{-1}$  from its lower end, and escapes through the upper end as shown in the figure. The cross-sectional area of the lower end is  $A_1 = 0.1 \text{ m}^2$  and the upper end is  $A_2 = 0.4 \text{ m}^2$ . The pressure and the temperature of the gas at the lower end are 600 Pa and 300 K, respectively, while its temperature at the upper end is 150 K. The chimney is heat insulated so that the gas undergoes adiabatic expansion. [Take:  $g = 10 \text{ ms}^{-2}$  and the ratio of specific heats of the gas  $\gamma = 2$ . Ignore atmospheric pressure.]

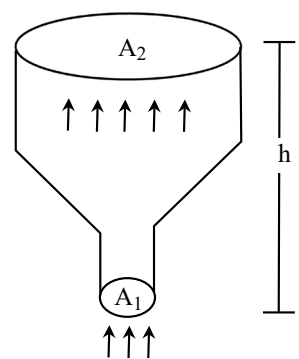

[JEE(Advanced) 2022]

Which of the following statement(s) is(are) correct?

- (A) The pressure of the gas at the upper end of the chimney is 300 Pa.
- (B) The velocity of the gas at the lower end of the chimney is  $40 \text{ ms}^{-1}$  and at the upper end is  $20 \text{ ms}^{-1}$ .
- (C) The height of the chimney is 590 m.
- (D) The density of the gas at the upper end is  $0.05 \text{ kg m}^{-3}$ .

5. A bubble has surface tension  $S$ . The ideal gas inside the bubble has ratio of specific heats  $\gamma = \frac{5}{3}$ . The bubble is exposed to the atmosphere and it always retains its spherical shape. When the atmospheric pressure is  $P_{a1}$ , the radius of the bubble is found to be  $r_1$  and the temperature of the enclosed gas is  $T_1$ . When the atmospheric pressure is  $P_{a2}$ , the radius of the bubble and the temperature of the enclosed gas are  $r_2$  and  $T_2$ , respectively.

Which of the following statement(s) is(are) correct?

[JEE(Advanced) 2022]

(A) If the surface of the bubble is a perfect heat insulator, then 
$$\left(\frac{r_1}{r_2}\right)^5 = \frac{P_{a2} + \frac{2S}{r_2}}{P_{a1} + \frac{2S}{r_1}}$$

(B) If the surface of the bubble is a perfect heat insulator, then the total internal energy of the bubble including its surface energy does not change with the external atmospheric pressure.

(C) If the surface of the bubble is a perfect heat conductor and the change in atmospheric temperature is

negligible, then 
$$\left(\frac{r_1}{r_2}\right)^3 = \frac{P_{a2} + \frac{4S}{r_2}}{P_{a1} + \frac{4S}{r_1}}$$

(D) If the surface of the bubble is a perfect heat insulator, then 
$$\left(\frac{T_2}{T_1}\right)^{\frac{5}{2}} = \frac{P_{a2} + \frac{4S}{r_2}}{P_{a1} + \frac{4S}{r_1}}$$

6. A cylindrical tube, with its base as shown in the figure, is filled with water. It is moving down with a constant acceleration  $a$  along a fixed inclined plane with angle  $\theta = 45^\circ$ .  $P_1$  and  $P_2$  are pressures at points 1 and 2, respectively, located at the base of the tube. Let  $\beta = (P_1 - P_2)/(\rho g d)$ , where  $\rho$  is density of water,  $d$  is the inner diameter of the tube and  $g$  is the acceleration due to gravity. Which of the following statement(s) is(are) correct ?

[JEE(Advanced) 2021]

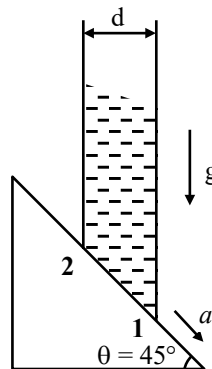

(A)  $\beta = 0$  when  $a = g/\sqrt{2}$

(B)  $\beta > 0$  when  $a = g/\sqrt{2}$

(C)  $\beta = \frac{\sqrt{2}-1}{\sqrt{2}}$  when  $a = g/2$

(D)  $\beta = \frac{1}{\sqrt{2}}$  when  $a = g/2$

Question Stem for Question Nos. 7 and 8

Question Stem

A soft plastic bottle, filled with water of density 1 gm/cc, carries an inverted glass test-tube with some air (ideal gas) trapped as shown in the figure. The test-tube has a mass of 5 gm, and it is made of a thick glass of density 2.5 gm/cc. Initially the bottle is sealed at atmospheric pressure  $p_0 = 10^5$  Pa so that the volume of the trapped air is  $v_0 = 3.3$  cc. When the bottle is squeezed from outside at constant temperature, the pressure inside rises and the volume of the trapped air reduces. It is found that the test tube begins to sink at pressure  $P_0 + \Delta p$  without changing its orientation. At this pressure, the volume of the trapped air is  $v_0 - \Delta v$ . Let  $\Delta v = X$  cc and  $\Delta p = Y \times 10^3$  Pa.

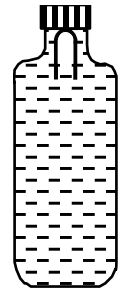

- 7. The value of  $X$  is \_\_\_\_\_. [JEE(Advanced) 2021]
- 8. The value of  $Y$  is \_\_\_\_\_. [JEE(Advanced) 2021]

- 9. An open-ended U-tube of uniform cross-sectional area contains water (density  $10^3 \text{ kg m}^{-3}$ ). Initially the water level stands at 0.29 m from the bottom in each arm. Kerosene oil (a water-immiscible liquid) of density  $800 \text{ kg m}^{-3}$  is added to the left arm until its length is 0.1 m, as shown in the schematic figure

below. The ratio  $\left(\frac{h_1}{h_2}\right)$  of the heights of the liquid in the two arms is- [JEE(Advanced) 2020]

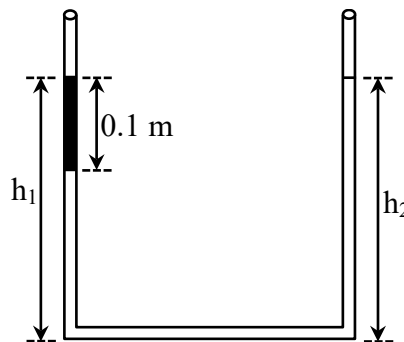

- (A)  $\frac{15}{14}$                       (B)  $\frac{35}{33}$                       (C)  $\frac{7}{6}$                       (D)  $\frac{5}{4}$

- 10. When water is filled carefully in a glass, one can fill it to a height  $h$  above the rim of the glass due to the surface tension of water. To calculate  $h$  just before water starts flowing, model the shape of the water above the rim as a disc of thickness  $h$  having semicircular edges, as shown schematically in the figure. When the pressure of water at the bottom of this disc exceeds what can be withstood due to the surface tension, the water surface breaks near the rim and water starts flowing from there. If the density of water, its surface tension and the acceleration due to gravity are  $10^3 \text{ kg m}^{-3}$ ,  $0.07 \text{ Nm}^{-1}$  and  $10 \text{ ms}^{-2}$ , respectively, the value of  $h$  (in mm) is \_\_\_\_\_. [JEE(Advanced) 2020]

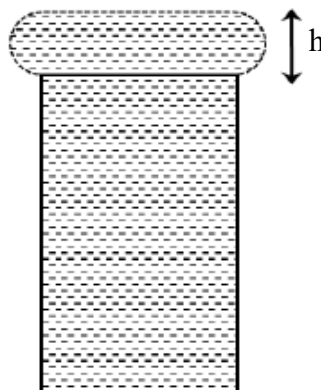

11. A train with cross-sectional area  $S_t$  is moving with speed  $v_t$  inside a long tunnel of cross-sectional area  $S_0$  ( $S_0 = 4S_t$ ). Assume that almost all the air (density  $\rho$ ) in front of the train flows back between its sides and the walls of the tunnel. Also, the air flow with respect to the train is steady and laminar. Take the ambient pressure and that inside the train to be  $p_0$ . If the pressure in the region between the sides of the train and the tunnel walls is  $p$ , then  $p_0 - p = \frac{7}{2N} \rho v_t^2$ . The value of  $N$  is \_\_\_\_\_. **[JEE(Advanced) 2020]**
12. A hot air balloon is carrying some passengers, and a few sandbags of mass 1 kg each so that its total mass is 480 kg. Its effective volume giving the balloon its buoyancy is  $V$ . The balloon is floating at an equilibrium height of 100 m. When  $N$  number of sandbags are thrown out, the balloon rises to a new equilibrium height close to 150 m with its volume  $V$  remaining unchanged. If the variation of the density of air with height  $h$  from the ground is  $\rho(h) = \rho_0 e^{-\frac{h}{h_0}}$ , where  $\rho_0 = 1.25 \text{ kg m}^{-3}$  and  $h_0 = 6000 \text{ m}$ , the value of  $N$  is \_\_\_\_\_. **[JEE(Advanced) 2020]**
13. A cubical solid aluminium (bulk modulus  $= -V \frac{dP}{dV} = 70 \text{ GPa}$ ) block has an edge length of 1 m on the surface of the earth. It is kept on the floor of a 5 km deep ocean. Taking the average density of water and the acceleration due to gravity to be  $10^3 \text{ kg m}^{-3}$  and  $10 \text{ ms}^{-2}$ , respectively, the change in the edge length of the block in mm is \_\_\_\_\_. **[JEE(Advanced) 2020]**
14. A cylindrical capillary tube of 0.2 mm radius is made by joining two capillaries T1 and T2 of different materials having water contact angles of  $0^\circ$  and  $60^\circ$ , respectively. The capillary tube is dipped vertically in water in two different configurations, case I and II as shown in figure. Which of the following option(s) is(are) correct ? **[JEE(Advanced) 2019]**  
(Surface tension of water = 0.075 N/m, density of water =  $1000 \text{ kg/m}^3$ , take  $g = 10 \text{ m/s}^2$ )

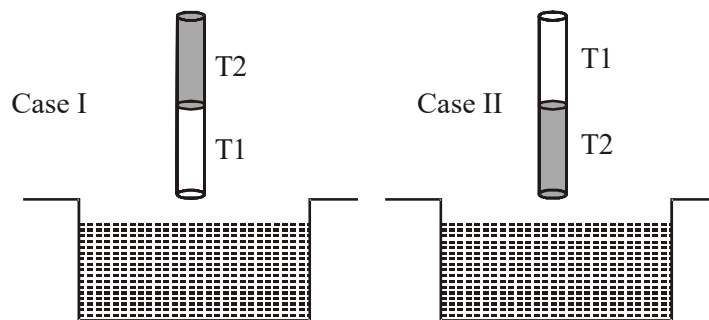

- (A) The correction in the height of water column raised in the tube, due to weight of water contained in the meniscus, will be different for both cases.
- (B) For case I, if the capillary joint is 5 cm above the water surface, the height of water column raised in the tube will be more than 8.75 cm. (Neglect the weight of the water in the meniscus)
- (C) For case I, if the joint is kept at 8 cm above the water surface, the height of water column in the tube will be 7.5 cm. (Neglect the weight of the water in the meniscus)
- (D) For case II, if the capillary joint is 5 cm above the water surface, the height of water column raised in the tube will be 3.75 cm. (Neglect the weight of the water in the meniscus)

15. A uniform capillary tube of inner radius  $r$  is dipped vertically into a beaker filled with water. The water rises to a height  $h$  in the capillary tube above the water surface in the beaker. The surface tension of water is  $\sigma$ . The angle of contact between water and the wall of the capillary tube is  $\theta$ . Ignore the mass of water in the meniscus. Which of the following statements is (are) true? [JEE(Advanced) 2018]
- (A) For a given material of the capillary tube,  $h$  decreases with increase in  $r$   
 (B) For a given material of the capillary tube,  $h$  is independent of  $\sigma$ .  
 (C) If this experiment is performed in a lift going up with a constant acceleration, then  $h$  decreases.  
 (D)  $h$  is proportional to contact angle  $\theta$ .
16. Consider a thin square plate floating on a viscous liquid in a large tank. The height  $h$  of the liquid in the tank is much less than the width of the tank. The floating plate is pulled horizontally with a constant velocity  $u_0$ . Which of the following statements is (are) true? [JEE(Advanced) 2018]
- (A) The resistive force of liquid on the plate is inversely proportional to  $h$   
 (B) The resistive force of liquid on the plate is independent of the area of the plate  
 (C) The tangential (shear) stress on the floor of the tank increases with  $u_0$ .  
 (D) The tangential (shear) stress on the plate varies linearly with the viscosity  $\eta$  of the liquid.
17. A drop of liquid of radius  $R = 10^{-2}$  m having surface tension  $S = \frac{0.1}{4\pi} \text{Nm}^{-1}$  divides itself into  $K$  identical drops. In this process the total change in the surface energy  $\Delta U = 10^{-3}$  J. If  $K = 10^\alpha$  then the value of  $\alpha$  is [JEE(Advanced) 2017]
18. Consider two solid spheres P and Q each of density  $8 \text{ gm cm}^{-3}$  and diameters 1 cm and 0.5 cm, respectively. Sphere P is dropped into a liquid of density  $0.8 \text{ gm cm}^{-3}$  and viscosity  $\eta = 3$  poiseulles. Sphere Q is dropped into a liquid of density  $1.6 \text{ gm cm}^{-3}$  and viscosity  $\eta = 2$  poiseulles. The ratio of the terminal velocities of P and Q is. [JEE(Advanced) 2016]
19. Two spheres P and Q of equal radii have densities  $\rho_1$  and  $\rho_2$ , respectively. The spheres are connected by a massless string and placed in liquids  $L_1$  and  $L_2$  of densities  $\sigma_1$  and  $\sigma_2$  and viscosities  $\eta_1$  and  $\eta_2$ , respectively. They float in equilibrium with the sphere P in  $L_1$  and sphere Q in  $L_2$  and the string being taut (see figure). If sphere P alone in  $L_2$  has terminal velocity  $\vec{V}_P$  and Q alone in  $L_1$  has terminal velocity  $\vec{V}_Q$ , then [JEE(Advanced) 2015]

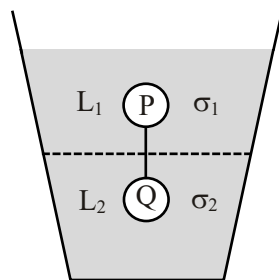

- (A)  $\frac{|\vec{V}_P|}{|\vec{V}_Q|} = \frac{\eta_1}{\eta_2}$       (B)  $\frac{|\vec{V}_P|}{|\vec{V}_Q|} = \frac{\eta_2}{\eta_1}$       (C)  $\vec{V}_P \cdot \vec{V}_Q > 0$       (D)  $\vec{V}_P \cdot \vec{V}_Q < 0$

20. A glass capillary tube is of the shape of truncated cone with an apex angle  $\alpha$  so that its two ends have cross sections of different radii. When dipped in water vertically, water rises in it to height  $h$ , where the radius of its cross section is  $b$ . If the surface tension of water is  $S$ , its density is  $\rho$ , and its contact angle with glass is  $\theta$ , the value of  $h$  will be ( $g$  is the acceleration due to gravity) **[JEE(Advanced) 2014]**

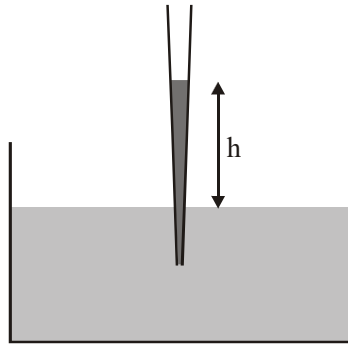

- (A)  $\frac{2S}{b\rho g} \cos(\theta - \alpha)$  (B)  $\frac{2S}{b\rho g} \cos(\theta + \alpha)$   
 (C)  $\frac{2S}{b\rho g} \cos(\theta - \alpha / 2)$  (D)  $\frac{2S}{b\rho g} \cos(\theta + \alpha / 2)$

**Paragraph for Questions No. 21 & 22**

A spray gun is shown in the figure where a piston pushes air out of a nozzle. A thin tube of uniform cross section is connected to the nozzle. The other end of the tube is in a small liquid container. As the piston pushes air through the nozzle, the liquid from the container rises into the nozzle and is sprayed out. For the spray gun shown, the radii of the piston and the nozzle are 20 mm and 1 mm respectively. The upper end of the container is open to the atmosphere. **[JEE(Advanced) 2014]**

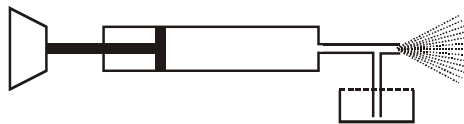

21. If the piston is pushed at a speed of  $5 \text{ mms}^{-1}$ , the air comes out of the nozzle with a speed of **[JEE(Advanced) 2014]**  
 (A)  $0.1 \text{ ms}^{-1}$  (B)  $1 \text{ ms}^{-1}$  (C)  $2 \text{ ms}^{-1}$  (D)  $8 \text{ ms}^{-1}$
22. If the density of air is  $\rho_a$  and that of the liquid  $\rho_\ell$ , then for a given piston speed the rate (volume per unit time) at which the liquid is sprayed will be proportional to **[JEE(Advanced) 2014]**  
 (A)  $\sqrt{\frac{\rho_a}{\rho_\ell}}$  (B)  $\sqrt{\rho_a \rho_\ell}$   
 (C)  $\sqrt{\frac{\rho_\ell}{\rho_a}}$  (D)  $\rho_\ell$

23. A person in a lift is holding a water jar, which has a small hole at the lower end of its side. When the lift is at rest, the water jet coming out of the hole hits the floor of the lift at a distance  $d$  of 1.2 m from the person. In the following, state of the lift's motion is given in List I and the distance where the water jet hits the floor of the lift is given in List II. Match the statements from List I with those in List II and select the correct answer using the code given below the lists. **[JEE(Advanced) 2014]**

**List-I**

- (P) Lift is accelerating vertically up.  
(Q) Lift is accelerating vertically down with an acceleration less than the gravitational acceleration.  
(R) Lift is moving vertically up with constant speed.  
(S) Lift is falling freely.

**List-II**

- (1)  $d = 1.2$  m  
(2)  $d > 1.2$  m  
(3)  $d < 1.2$  m  
(4) No water leaks out of the jar

**Code :**

- (A) P-2, Q-3, R-2, S-4  
(B) P-2, Q-3, R-1, S-4  
(C) P-1, Q-1, R-1, S-4  
(D) P-2, Q-3, R-1, S-1



SOLUTIONS

1. Ans. (25)

Sol.

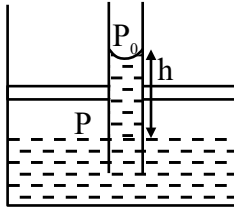

$$h_0 = \frac{2T \cos \theta}{\rho g r} = \frac{2 \times 0.075 \times 1}{10^3 \times 10 \times 10^{-4}} = 15 \text{ cm}$$

$$P_0 V_0 = P \frac{100 V_0}{101} \Rightarrow P = \frac{101}{100} P_0$$

$$P_0 - \frac{2T \cos \theta}{r} + \rho g h = P = \frac{101}{100} P_0$$

$$\Rightarrow -\rho g h_0 + \rho g h = \frac{P_0}{100}$$

$$\Rightarrow h = h_0 + \frac{P_0}{100 \rho g}$$

$$= 15 \text{ cm} + \frac{10^5}{100 \times 10^3 \times 10} = 25 \text{ cm}$$

2. Ans. (Dropped)

Sol.

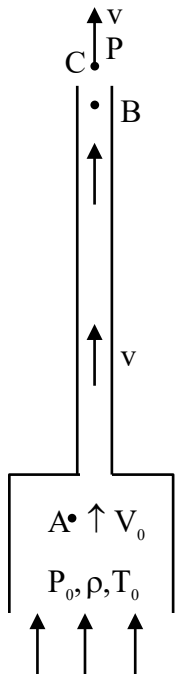

$$\rho_0 T_0 = \rho T$$

$$\Rightarrow 1.2 \times 300 = \rho(360) \therefore \rho = 1$$

Between A & B

$$P_0 + \frac{1}{2} \rho V_0^2 = P + \frac{1}{2} \rho V^2 + \rho g h \quad \dots(1)$$

$$\frac{\pi D^2}{4} V_0 = \frac{\pi d^2}{4} V \quad \dots(2)$$

Between B & C

$$P + \frac{1}{2} \rho V^2 = P_0 - \rho_0 g(H + h) + \frac{1}{2} \rho V^2 \quad \dots(3)$$

from (1) & (2) :

$$\Rightarrow P_0 + \frac{1}{2} \rho \left( V \frac{d^2}{D^2} \right)^2 = P + \frac{1}{2} \rho V^2 + \rho g h$$

$$\Rightarrow \rho_0 g(H + h) = \frac{1}{2} \rho V^2 \left[ 1 - \frac{d^4}{D^4} \right] + \rho g h$$

$$\Rightarrow V^2 \approx \frac{2 \rho_0}{\rho} g(H + h) - 2 g h$$

$$= 2 \times 1.2 \times 10 \times 10 - 2 \times 10 \times 9$$

$$= 240 - 180 = 60 \therefore V = \sqrt{60} \text{ m/s}$$

$$Q_m = \rho \frac{\pi d^2}{4} V = 1 \times \frac{\pi}{4} \times 10^{-2} \times \sqrt{60} \approx 60.80$$

Ans. (60.80 to 60.81)

3. Ans. (Dropped)

Sol.

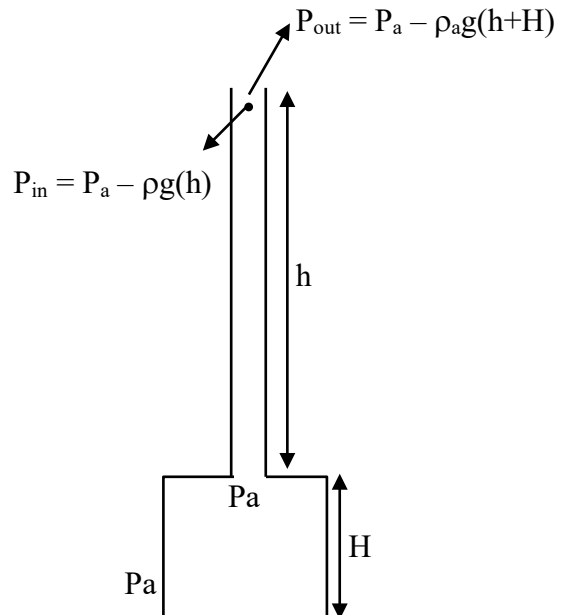

P = constant

$$\Rightarrow \rho_a T_a = \rho T$$

$$1.2 \times 300 = \rho \times 360$$

$$\rho = 1 \text{ kg/m}^3$$

$$\Delta P = \rho_a g(h + H) - \rho g h$$

$$= 1.2 \times 10 \times 10 - 1 \times 10 \times 9$$

$$= 120 - 90 = 30 \text{ N/m}^2$$

4. Ans. (B)

Sol.

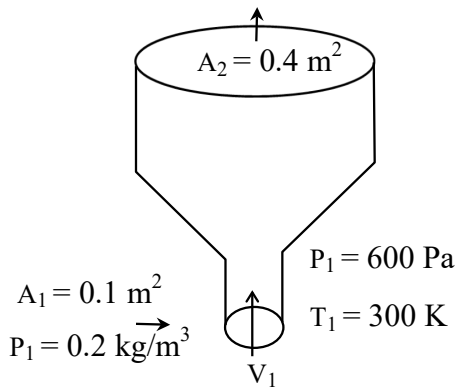

$$\frac{dm}{dt} = \rho_1 A_1 v_1 = 0.8 \text{ kg/s}$$

$$v_1 = \frac{0.8}{0.2 \times 0.1} = 40 \text{ m/s}$$

$$g = 10 \text{ m/s}^2$$

$$\gamma = 2$$

Gas undergoes adiabatic expansion,

$$P^{1-\gamma} T^\gamma = \text{Constant}$$

$$\frac{P_2}{P_1} = \left( \frac{T_1}{T_2} \right)^{\frac{\gamma}{1-\gamma}}$$

$$P_2 = \left( \frac{300}{150} \right)^{-2} \times 600$$

$$P_2 = \frac{600}{4} = 150 \text{ Pa}$$

$$\text{Now, } \rho = \frac{PM}{RT} \Rightarrow \rho \propto \frac{P}{T}$$

$$\frac{\rho_1}{\rho_2} = \left( \frac{P_1}{P_2} \right) \left( \frac{T_1}{T_2} \right) = \left( \frac{150}{600} \right) \left( \frac{300}{150} \right) = \frac{1}{2}$$

$$\rho_2 = \frac{\rho_1}{2} = 0.1 \text{ kg/m}^3$$

$$\text{Now, } \rho_2 A_2 v_2 = 0.8 \Rightarrow v_2 = \frac{0.8}{0.1 \times 0.4} = 20 \text{ m/s}$$

Now,  $W_{\text{on gas}} = \Delta K + \Delta U + (\text{Internal energy})$

$$P_1 A_1 \Delta x_1 - P_2 A_2 \Delta x_2 =$$

$$\frac{1}{2} \Delta m V_2^2 - \frac{1}{2} \Delta m V_1^2 + \Delta m g h$$

$$+ \frac{f}{2} (P_2 \Delta V_2 - P_1 \Delta V_1)$$

$$\Rightarrow 2P_1 \frac{\Delta V_1}{\Delta m} - 2P_2 \frac{\Delta V_2}{\Delta m} = \frac{V_2^2 - V_1^2}{2} + g h$$

$$\Rightarrow \frac{2 \times 600}{0.2} - \frac{2 \times 150}{0.1} = \frac{20^2 - 40^2}{2} + 10h$$

$$h = 360 \text{ m}$$

5. Ans. (C, D)

Sol.

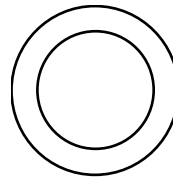

$$P_{\text{gas}} = P_a + \frac{4S}{r}$$

$$PV^\gamma = \text{constant [adiabatic process]}$$

$$\left( P_{a_1} + \frac{4S}{r_1} \right) \left( \frac{4}{3} \pi r_1^3 \right)^{5/3} = \left( P_{a_2} + \frac{4S}{r_2} \right) \left( \frac{4}{3} \pi r_2^3 \right)^{5/3}$$

$$\frac{r_1^3}{r_2^3} = \frac{\left( P_{a_2} + \frac{4S}{r_2} \right)}{\left( P_{a_1} + \frac{4S}{r_1} \right)}$$

$$P^{1-\gamma} T^\gamma = \text{constant}$$

$$\left( P_{a_2} + \frac{4S}{r_2} \right)^{1-5/3} T_2^{5/3} = \left( P_{a_1} + \frac{4S}{r_1} \right)^{1-5/3} T_1^{5/3}$$

$$\left( \frac{T_2}{T_1} \right)^{5/3} = \left( \frac{P_{a_1} + \frac{4S}{r_1}}{P_{a_2} + \frac{4S}{r_2}} \right)^{-2/3}$$

$$\left( \frac{T_2}{T_1} \right)^{5/2} = \left( \frac{P_{a_2} + \frac{4S}{r_2}}{P_{a_1} + \frac{4S}{r_1}} \right)$$

6. Ans. (A,C)

Sol.

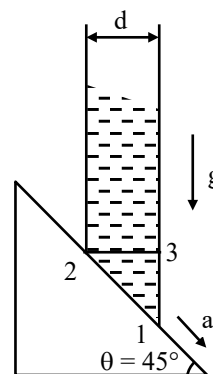

$$\therefore P_1 - P_3 = \rho \left( g - \frac{a}{\sqrt{2}} \right) d$$

$$P_2 - P_3 = \rho \frac{a}{\sqrt{2}} d$$

$$\therefore P_1 - P_2 = \rho d \left[ g - \frac{2a}{\sqrt{2}} \right]$$

$$\therefore \frac{P_1 - P_2}{\rho g d} = \left[ 1 - \sqrt{2} \frac{a}{g} \right] = \beta$$

$$\therefore \text{if } \beta = 0, a = \frac{g}{\sqrt{2}} \quad \dots(A)$$

$$\beta = \frac{\sqrt{2}-1}{2}, a = \frac{g}{2} \quad \dots(C)$$

7. **Ans. (0.30)**

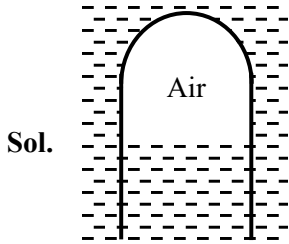

Sol.

When it starts sinking

$$F_B = mg$$

$$\rho_0 (V_{\text{glass}} + V_{\text{gas}}) = m$$

$$1(2 + V_{\text{gas}}) = 5 \Rightarrow V_{\text{gas}} = 3 \text{ cc}$$

Hence  $\Delta V = 0.3 \text{ cc}$ .

8. **Ans. (10.00)**

Sol. Isothermal process for air

$$P_1 V_1 = P_2 V_2$$

$$10^5 (3.3) = P_2 (3)$$

$$P_2 = 1.1 \times 10^5$$

$$\Delta P = P_2 - P_1 = 1.1 \times 10^5 - 10^5$$

$$= 0.1 \times 10^5 = 10 \times 10^3 \text{ Pascal}$$

$$= Y \times 10^3 \text{ Pascal}$$

$$\text{So } Y = 10$$

9. **Ans. (B)**

Sol.  $h_1 + h_2 = 0.29 \times 2 + 0.1$

$$h_1 + h_2 = 0.68 \quad \dots(1)$$

$$\Rightarrow P_0 + \rho_k g(0.1) + \rho_w g(h_1 - 0.1)$$

$[\rho_k = \text{density of kerosene \&}$

$\rho_w = \text{density of water}]$

$$-\rho_w g h_2 = P_0$$

$$\Rightarrow \rho_k g(0.1) + \rho_w g h_1 - \rho_w g \times (0.1) = \rho_w g h_2$$

$$\Rightarrow 800 \times 10 \times 0.1 + 1000 \times 10 \times h_1$$

$$-1000 \times 10 \times 0.1 = 1000 \times 10 \times h_2$$

$$\Rightarrow 10000 (h_1 - h_2) = 200$$

$$\Rightarrow h_1 - h_2 = 0.02 \quad \dots(2)$$

$$\Rightarrow \boxed{h_1 = 0.35}$$

$$\Rightarrow \boxed{h_2 = 0.33}$$

So,  $\boxed{\frac{h_1}{h_2} = \frac{35}{33}}$

10. **Ans. (3.65 to 3.85)**

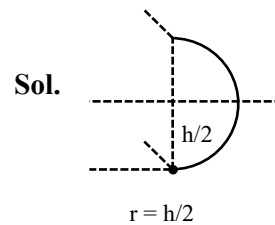

Sol.

Pressure at the bottom of disc = pressure due to surface tension

$$\rho g h = T \left( \frac{1}{R_1} + \frac{1}{R_2} \right)$$

$$R_1 \gg \gg R_2$$

$$\text{So } \frac{1}{R_1} \ll \ll \frac{1}{R_2} \text{ and } R_2 = h/2$$

$$\therefore \rho g h = T \left[ \frac{1}{R_1} + \frac{1}{R_2} \right] = T \left[ 0 + \frac{1}{h/2} \right]$$

$$h^2 = \frac{2T}{\rho g}$$

$$h = \sqrt{\frac{2T}{\rho g}} = \sqrt{\frac{2 \times 0.07}{10^3 \times 10}} = \sqrt{\frac{14 \times 100}{10^4 \times 100}}$$

$$h = \sqrt{14} \text{ mm} = 3.741$$

11. **Ans. (9)**

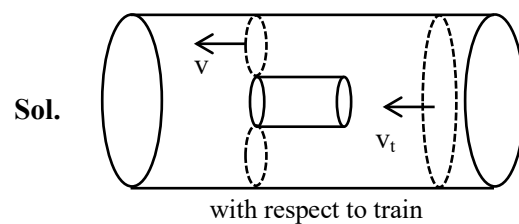

Sol.

Applying Bernoulli's equation

$$P_0 + \frac{1}{2} \rho v_t^2 = P + \frac{1}{2} \rho v^2$$

$$P_0 - P = \frac{1}{2} \rho (v^2 - v_t^2) \quad \dots(i)$$

From equation of continuity

$$\text{Also, } 4S_t v_t = v \times 3S_t \Rightarrow v = \frac{4}{3} v_t \quad \dots(ii)$$

From (i) and (ii)

$$P_0 - P = \frac{1}{2} \rho \left( \frac{16}{9} v_t^2 - v_t^2 \right) = \frac{1}{2} \rho \frac{7v_t^2}{9}$$

$$\therefore N = 9$$

12. Ans. (4)

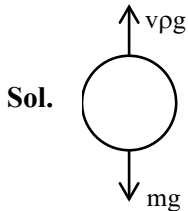

$$480 \times g = v\rho_1 g$$

$$(480 - N)g = v\rho_2 g$$

$$\frac{480 - N}{480} = \frac{\rho_2}{\rho_1}$$

$$\left( 1 - \frac{N}{480} \right) = \frac{e^{-h_2/h_0}}{e^{-h_1/h_0}} = e^{\frac{h_1 - h_2}{h_0}} = e^{\frac{50}{6000}}$$

$$1 - \frac{N}{480} = 1 - \frac{50}{6000} \Rightarrow N = \frac{50 \times 480}{6000} = 4$$

13. Ans. (0.23 to 0.25 or -0.23 to -0.25)

Sol.  $\frac{dV}{V} = \frac{3da}{a}$

$$B = -V \frac{dP}{dV} = \frac{-V(\rho gh)}{dV} = \frac{-\rho gh}{3da} a$$

$$70 \times 10^9 = \frac{1 \times 5000 \times 10^3 \times 10 \times 1}{3 \times da}$$

$$da = \Delta a = \frac{5}{21} \times 10^{-2} \text{ m} = 2.38 \text{ mm}$$

14. Ans. (A, C, D)

Sol.  $h = \frac{2T \cos \theta}{\rho g R}$  ;  $h_1 = \frac{2 \times 0.075 \times \cos 0^\circ}{1000 \times 10 \times 0.2 \times 10^{-3}}$

$$\Rightarrow h_1 = 75 \text{ mm (in T1)}$$

[If we assume entire tube of T1]

$$\Rightarrow h_2 = \frac{2 \times 0.075 \times \cos 60^\circ}{1000 \times 10 \times 0.2 \times 10^{-3}}$$

$$= 37.5 \text{ mm (in T2)}$$

[If we assume entire tube of T2]

Option (A) : Since contact angles are different so correction in the height of water column raised in the tube will be different in both the cases, so option (A) is correct

Option (B) : If joint is 5 cm is above water surface, then lets say water crosses the joint by height h, then:

$$\Rightarrow P_0 - \frac{2T}{r} + \rho gh + \rho g \times 5 \times 10^{-2} = P_0$$

$$\Rightarrow \cos \theta = \frac{R}{r}, r = \frac{R}{\cos \theta}$$

$$\Rightarrow \rho g(h + 5 \times 10^{-2}) = \frac{2T \cos \theta}{R}$$

$$\Rightarrow h = \frac{2 \times 0.075 \times \cos 60}{0.2 \times 10^{-3} \times 1000 \times 10} - 5 \times 10^{-2}$$

$\Rightarrow h = -ve$ , not possible, so liquid will not cross the interface, but angle of contact at the interface will change, to balance the pressure, So, option (B) is wrong.

Option (C) : If interface is 8 cm above water then water will not even reach the interface, and water will rise till 7.5 cm only in T1, so option (C) is right.

Option (D) : If interface is 5 cm above the water in vessel, then water in capillary will not even reach the interface. Water will reach only till 3.75 cm, so option (D) is right.

15. Ans. (A, C)

Sol.  $\frac{2\sigma}{R} = \rho gh$  [R → Radius of meniscus]

$$h = \frac{2\sigma}{R\rho g} \quad R = \frac{r}{\cos \theta}$$

[r → radius of capillary;  $\theta$  → contact angle]

$$h = \frac{2\sigma \cos \theta}{r\rho g}$$

(A) For given material,  $\theta$  → constant

$$h \propto \frac{1}{r}$$

(B) h depend on  $\sigma$

(C) If lift is going up with constant acceleration,  $g_{\text{eff}} = (g + a)$

$$h = \frac{2\sigma \cos \theta}{r\rho(g+a)} \text{ It means h decreases}$$

(D) h is proportional to  $\cos \theta$  Not  $\theta$

16. Ans. (A, C, D)

Sol.

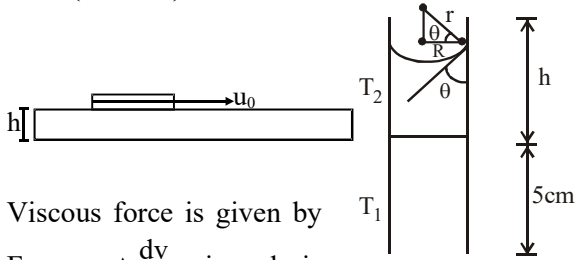

Viscous force is given by  
 $F = -\eta A \frac{dv}{dy}$  since h is

very small therefore, magnitude of viscous force is given by

$$F = \eta A \frac{\Delta v}{\Delta y}$$

$$\therefore F = \frac{\eta A u_0}{h} \Rightarrow F \propto \eta \text{ \& } F \propto u_0 ;$$

$$F \propto \frac{1}{h}, F \propto A$$

Since plate is moving with constant velocity, same force must be acting on the floor.

17. Ans. (6)

Sol. By mass conservation,  $\rho_b \cdot \frac{4}{3} \pi R^3 = \rho \cdot K \cdot \frac{4}{3} \pi r^3$

$$\frac{R}{r}, r = \frac{R}{\cos \theta}$$

$$\Rightarrow R = K^{1/3} r$$

$$\therefore \Delta U = T \Delta A = T (K \cdot 4\pi r^2 - 4\pi R^2)$$

$$= T (K \cdot 4\pi R^2 K^{-2/3} - 4\pi R^2)$$

$$\Delta U = 4\pi R^2 T [K^{1/3} - 1]$$

Putting the value's  $\Rightarrow$

$$10^{-3} = \frac{10^{-1}}{4\pi} \times 4\pi \times 10^{-4} [K^{1/3} - 1]$$

$$100 = K^{1/3} - 1 \Rightarrow K^{1/3} \cong 100 = 10^2$$

$$\text{Given that } K = 10^\alpha \Rightarrow \therefore 10^{\alpha/3} = 10^2$$

$$\Rightarrow \frac{\alpha}{3} = 2 \Rightarrow \alpha = 6$$

18. Ans. (3)

Sol.  $V_T \propto \frac{r^2 [d_m - d_L]}{n}$

$$\frac{V_{TP}}{V_{TQ}} = \left(\frac{r_P}{r_Q}\right)^2 \times \frac{n_{L_2}}{n_{L_1}} \times \left[\frac{d_m - d_{L_1}}{d_m - d_{L_2}}\right]$$

$$\frac{V_{TP}}{V_{TQ}} = \left(\frac{2}{1}\right)^2 \times \frac{2}{3} \times \left[\frac{8 - 0.8}{8 - 1.6}\right]$$

$$\frac{V_{TP}}{V_{TQ}} = 3$$

19. Ans. (A, D)

Sol. Consider a body of density  $\rho_b$  kept in density  $\rho_\ell$  whose viscosity is  $\eta$  and terminal velocity  $V$ . Then

$$\vec{F}_{\text{viscous}} + \vec{F}_{\text{mg}} + \vec{F}_{\text{Buoyancy}} = 0$$

$$\vec{F}_{\text{viscous}} + \rho_b \frac{4}{3} \pi R^3 (-\hat{j}) + \rho_\ell \frac{4}{3} \pi R^3 (\hat{j}) = 0$$

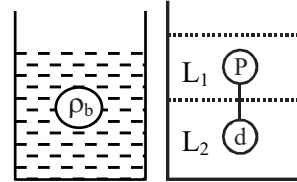

$$\therefore \vec{F}_{\text{viscous}} = (\rho_b - \rho_\ell) \frac{4}{3} \pi R^3 (\hat{j})$$

$$\Rightarrow 6\pi\eta RV = (\rho_b - \rho_\ell) \frac{4}{3} \pi R^3$$

$$\therefore \text{if } \rho_b > \rho_\ell \text{ then } \vec{F}_{\text{viscous}} \uparrow \quad V \propto \frac{1}{\eta} \text{ \& }$$

$$\text{if } \rho_b < \rho_\ell \quad \vec{F}_{\text{viscous}} \downarrow$$

as per given diagram we can say

$$\sigma_2 > \sigma_1 ; \rho_1 < \sigma_1 \text{ \& } \rho_2 > \sigma_2$$

$$\Rightarrow \rho_2 > \sigma_2 > \sigma_1 > \rho_1$$

$$\therefore \text{if we put P in } L_2 \text{ where } |\vec{V}_P| \propto \frac{1}{\eta_2}$$

$$\text{when } \rho_1 < \sigma_2 \therefore \vec{F}_{\text{viscous}} \downarrow \therefore \vec{V}_P \uparrow$$

$$\therefore \text{if we put Q in } L_1 \text{ where } |\vec{V}_Q| \propto \frac{1}{\eta_1}$$

$$\text{when } \rho_2 > \sigma_1 \therefore \vec{F}_{\text{viscous}} \uparrow \therefore \vec{V}_P \downarrow$$

$$\Rightarrow \frac{|\vec{V}_P|}{|\vec{V}_Q|} = \frac{\eta_1}{\eta_2} \text{ \& }$$

$$\vec{V}_P \cdot \vec{V}_Q < 0$$

20. Ans. (D)

Sol.  $\cos\left(\theta + \frac{\alpha}{2}\right) = \frac{b}{R}$

$$R = \frac{b}{\cos\left(\theta + \frac{\alpha}{2}\right)}$$

$$P_A = P_0$$

$$P_B = P_0 - \frac{25}{R}$$

$$\Rightarrow P_C = P_B + \rho gh = P_0$$

$$P_0 - \frac{2S}{R} + \rho gh = P_0 \Rightarrow h = \frac{2S}{\rho gb} \cos\left(\theta + \frac{\alpha}{2}\right)$$

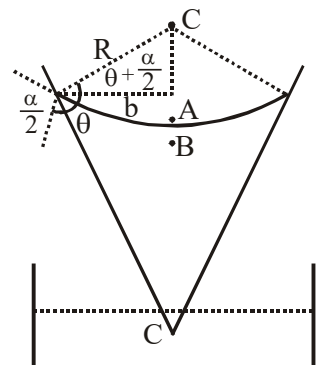

21. Ans. (C)

Sol. By equation of continuity

$$A_1 V_1 = A_2 V_2$$

$$(5 \text{ mm/sec}) \pi (20)^2 = \pi (1)^2 V_2$$

$$V_2 = 2000 \text{ mm/sec}$$

$$V_2 = 2.00 \text{ m/sec}$$

22. Ans. (A)

Sol. By applying conservation of energy

$$\frac{1}{2} \rho_A V^2 = \frac{1}{2} \rho_L V^2 + \rho_L g H$$

Assuming height of liquid is negligible

$$V \propto \sqrt{\frac{\rho_A}{\rho_L}}$$

23. Ans. (C)

Sol.

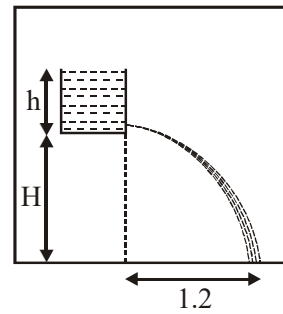

Horizontal displacement =

$$\sqrt{2g_{\text{eff}} h} \cdot \sqrt{\frac{2H}{g_{\text{eff}}}} = \sqrt{4hH}$$

Since  $g_{\text{eff}}$  cancelled out therefore distance will be same in case P, Q and R.

When lift falls freely no water leaks out of Jar.