

MATHEMATICS**(BASIC)****TIME : 3 HRS.****MAX. MARKS : 80****GENERAL INSTRUCTIONS :**

- ▶ All questions are compulsory.
- ▶ The question paper consists of 38 questions divided into five sections A, B, C, D and E.
- ▶ Section A contains multiple choice questions (Q.1 to Q.18) and Assertion-Reason based questions (Q.19 & Q.20) of one mark each, only the correct option is to be written in your answer sheet.
Section B contains short answer type questions (Q.21 to Q.25) carrying two marks each.
Section C contains short answer type questions (Q.26 to Q.31) carrying three marks each.
Section D contains long answer type questions (Q.32 to Q.35) carrying five marks each.
Section E has 3 case based integrated units of assessment 4 marks each with sub-parts of the values of 1, 1 and 2 marks each respectively.
- ▶ All Questions are compulsory. However, an internal choice in 2 Qs of 5 marks, 2 Qs of 3 marks and 2 Questions of 2 marks has been provided. An internal choice has been provided in the 2 marks sub-part of each question of Section E
- ▶ There is no overall choice. However, internal choice may be provided. You have to attempt only one of the alternatives in all such questions.
- ▶ Use of calculators and cell-phones are not permitted in the Examination Hall.

SECTION-A

1. $(7 \times 11 \times 13 \times 15) + 15$ is a
(1) composite number (2) whole number (3) prime number (4) both (1) and (2)
2. The least number that is divisible by all the numbers from 1 to 10 (both inclusive) is
(1) 10 (2) 100 (3) 504 (4) 2,520
3. The quadratic equation $2x^2 - \sqrt{5}x + 1 = 0$ has
(1) two distinct real roots (2) two equal real roots
(3) no real roots (4) more than 2 real roots
4. Find the number of solutions for given pair of equations : $2x + 2y = 2$ and $x + y = 1$.
(1) unique solution (2) infinite solution
(3) no solution (4) exactly two solutions
5. If the quadratic equation $x^2 + 4x + k = 0$ has real and equal roots, then
(1) $k < 4$ (2) $k > 4$ (3) $k = 4$ (4) $k \geq 4$
6. In which ratio the y-axis divides the line segment joining the points (5, -6) and (-1, -4)?
(1) 1 : 5 (2) 5 : 1 (3) 1 : 1 (4) 1 : 2

7. In the following figure, Q is a point on PR and S is a point in TR. QS is drawn and $\angle RPT = \angle RQS$. Which of these criteria can be used to prove that ΔRSQ is similar to ΔRTP ?

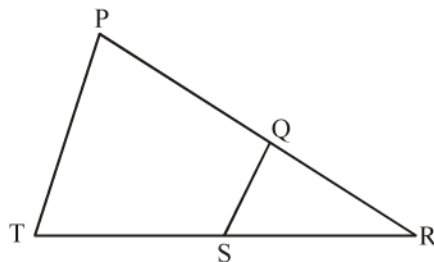

- (1) AAA similarity criterion
 (2) SAS similarity criterion
 (3) SSS similarity criterion
 (4) RHS similarity criterion
8. If in triangles ABC and EDF, $\frac{AB}{DE} = \frac{BC}{FD}$ then they will be similar, when :
- (1) $\angle B = \angle E$ (2) $\angle A = \angle D$ (3) $\angle B = \angle D$ (4) $\angle A = \angle F$
9. In the figure, if PA and PB are tangents to the circle with centre O such that $\angle APB = 50^\circ$, then $\angle OAB$ is equal to

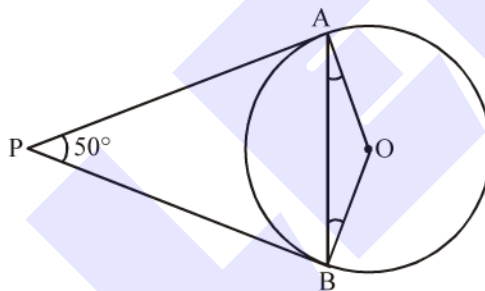

- (1) 25° (2) 30° (3) 40° (4) 50°
10. $\sqrt{3} \cos^2 A + \sqrt{3} \sin^2 A$ is equal to
- (1) 1 (2) $\frac{1}{\sqrt{3}}$ (3) $\sqrt{3}$ (4) 0
11. If the ratio of the length of a rod to its shadow is $1:\sqrt{3}$, then angle of elevation of the sun is
- (1) 30° (2) 60° (3) 45° (4) 90°
12. If $\sin A = \frac{1}{2}$ then the value of $\cos A$ is
- (1) $\sqrt{3}$ (2) $\frac{1}{\sqrt{3}}$ (3) $\frac{\sqrt{3}}{2}$ (4) 1
13. The radii of two concentric circles are 4 cm and 5 cm. The difference in the areas of these two circles is
- (1) π (2) 7π (3) 9π (4) 13π

14. A wire is in the shape of a circle of radius 21 cm. It is bent to form a square. The side of the square is
 (1) 22 cm (2) 33 cm (3) 44 cm (4) 66 cm
15. Riya and Kajal are friends. The probability that both will have the same birthday in a non-leap year is
 (1) $\frac{364}{365}$ (2) $\frac{31}{365}$ (3) $\frac{1}{365}$ (4) $\frac{1}{133225}$
16. For the following distribution :

Marks	Number of students
Below 10	3
Below 20	12
Below 30	27
Below 40	57
Below 50	75
Below 60	80

- the modal class is
 (1) 10 – 20 (2) 20 – 30 (3) 30 – 40 (4) 50 – 60
17. Consider the following frequency distribution :

Class	0-5	6-11	12-17	18-23	24-29
Frequency	13	10	15	8	11

- the upper limit of the median class is :
 (1) 7 (2) 17.5 (3) 18 (4) 18.5
18. The total surface area of a solid hemisphere of radius 7 cm is
 (1) $447 \pi \text{ cm}^2$ (2) $239 \pi \text{ cm}^2$ (3) $174 \pi \text{ cm}^2$ (4) $147 \pi \text{ cm}^2$
19. **Assertion (A) :** The value of y is 6, for which the distance between the points $P(2, -3)$ and $Q(10, y)$ is 10.
Reason (R) : Distance between two given points $A(x_1, y_1)$ and $B(x_2, y_2)$ is given by
 $AB = \sqrt{(x_2 - x_1)^2 + (y_2 - y_1)^2}$
 (1) Both Assertion (A) and Reason (R) are true and Reason (R) is the correct explanation of Assertion (A).
 (2) Both Assertion (A) and Reason (R) are true but Reason (R) is not the correct explanation of Assertion (A).
 (3) Assertion (A) is true but Reason (R) is false.
 (4) Assertion (A) is false but Reason (R) is true.
20. **Assertion (A) :** The HCF of two numbers is 6 and their product is 360, then their LCM is 60.
Reason (R) : For any two positive integers a and b , $\text{HCF}(a, b) \times \text{LCM}(a, b) = a \times b$.
 (1) Both Assertion (A) and Reason (R) are true and Reason (R) is the correct explanation of Assertion (A).
 (2) Both Assertion (A) and Reason (R) are true but Reason (R) is not the correct explanation of Assertion (A).
 (3) Assertion (A) is true but Reason (R) is false.
 (4) Assertion (A) is false but Reason (R) is true.

SECTION-B

- 21. Find c if the system of equations $cx + 3y + (3 - c) = 0$; $12x + cy - c = 0$ has infinitely many solutions.
- 22. E is a point on the side AD produced of a parallelogram $ABCD$ and BE intersects CD at F . Show that $\triangle ABE \sim \triangle CFB$.

OR

In the given figure, if $AB \parallel CD$, then the value of x is

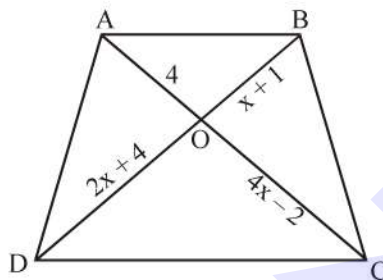

- 23. PQ is a tangent drawn from a point P to a circle with centre O and QOR is a diameter of the circle such that $\angle POR = 120^\circ$, then find $\angle OPQ$.

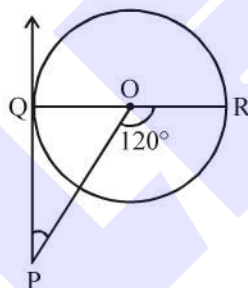

- 24. If $\tan A = \frac{3}{4}$, find the value of $\frac{1}{\sin A} + \frac{1}{\cos A}$.
- 25. Find the area of a quadrant of a circle where the circumference of circle is 176 m.

OR

In the given figure, find the perimeter of the sector of a circle with radius 10.5 cm and of angle 60° .

(Take $\pi = \frac{22}{7}$).

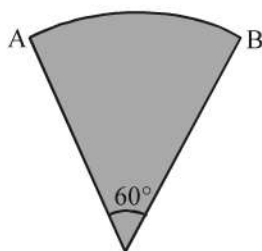

SECTION-C

26. Given that $\sqrt{3}$ is an irrational number, show that $(5 + 2\sqrt{3})$ is an irrational number.
27. Without actually calculating the zeroes, form a quadratic polynomial whose zeroes are reciprocals of the zeroes of the polynomial $5x^2 + 2x - 3$.
28. Raghav scored 70 marks in a test, getting 4 marks for each right answer and losing 1 mark for each wrong answer. By mistake, examiner awarded 5 marks for each correct answer and deducted 2 marks for each wrong answer, then Raghav would have scored 80 marks. How many questions were there in the test?

OR

If twice the son's age in years is added to the father's age, the sum is 70. But if twice the father's age is added to the son's age, the sum is 95. Find the ages of father and son.

29. In given figure, PQ and PR are tangents to the circle centred at O. If $\angle OPR = 45^\circ$, then prove that ORPQ is a square.

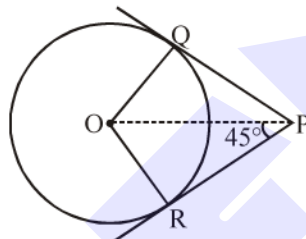

30. If $\sin(A + 2B) = \frac{\sqrt{3}}{2}$ and $\cos(A + 4B) = 0$, $A > B$, and $A, B \leq 90^\circ$, then find A and B.

OR

Evaluate : $4(\sin^4 30^\circ + \cos^4 60^\circ) - 3(\cos^2 45^\circ - \sin^2 90^\circ)$

31. A bag contains 24 balls of which x are red, 2x are white and 3x are blue. A ball is drawn at random. What is the probability that it is
- not a red ball?
 - a white ball?
 - either a blue or a white ball?

SECTION-D

32. Places A and B are 80 km apart from each other on a highway. A car starts from A and another from B at the same time. If they move in same direction they meet in 8 hours and if they move towards each other they meet in 1 hour 20 minutes. Find the speed of cars.

OR

5 pencils and 7 pens together cost Rs.250 whereas 7 pencils and 5 pens together cost Rs.302. Find the cost of one pencil and that of a pen.

33. Prove that the line segments joining the midpoints of the sides of a triangle form four triangles, each of which is similar to the original triangle.

OR

In a ΔABC , P and Q are points on AB and AC respectively such that $PQ \parallel BC$. Prove that the median AD, drawn from A to BC, bisects PQ.

34. A solid iron pole, consists of a cylinder of height 220 cm and base diameter 24 cm, which is surmounted by another cylinder of height 60 cm and radius 8 cm. Find the mass of the pole, that 1 cm³ of iron has approximately 8 g mass. (Use $\pi = 3.14$)

OR

Isha is 10 years old girl. On the result day, Isha and her father Suresh were very happy as she got first position in the class. While coming back to their home, Isha asked for a treat from her father as a reward for her success. They went to a juice shop and asked for two glasses of juice.

Aisha, a juice seller, was serving juice to her customers in two type of glasses. Both the glasses had inner radius 3 cm. The height of both the glasses was 10 cm.

First type : A glass with hemispherical raised bottom.

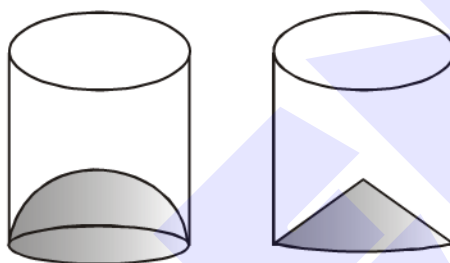

Second type : A glass with conical raised bottom of height 1.5 cm.

Isha insisted to have the juice in first type of glass and her father decided to have the juice in second type of glass. Out of the two, Isha or her father Suresh, who got more quantity of juice to drink and by how much?

35. If the median for the distribution given below is 28.5, then find the values of x and y.

Class interval	Frequency
0-10	5
10-20	x
20-30	20
30-40	15
40-50	y
50-60	5
Total	60

SECTION-E

36. Case Study-1

An electrician has to repair an electric fault on the pole of height 5 m. He needs to reach a point 1.3 m below the top of the pole to undertake the repair work (see figure).

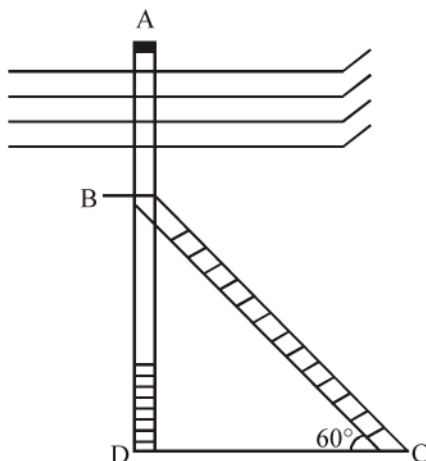

- (i) What is the length of BD? (1)
- (ii) What should be the length of ladder, when inclined at an angle of 60° to the horizontal? (1)
- (iii) How far from the foot of the pole should he place the foot of the ladder if angle of inclination of ladder is 60° . (2)

OR

If the angle of inclination is changed to 30° , then what should be the length of the ladder?(2)

37. Case Study-2

In a room, 4 friends are seated at the points A, B, C and D as shown in figure. Reeta and Meeta walk into the room and after observing for a few minutes, Reeta asks Meeta.

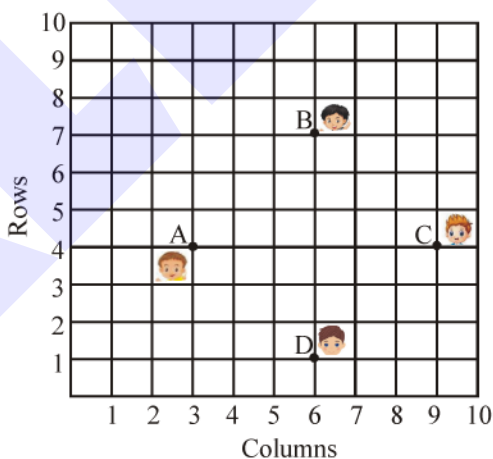

- (i) What is the position of A and D? (1)
- (ii) What is the distance between A and B? (2)

OR

Write coordinates of point that divides AB in ratio 3 : 1 (2)

- (iii) What is the mid point of B and C? (1)

38. Case Study-3

A ladder has rungs 25 cm apart.

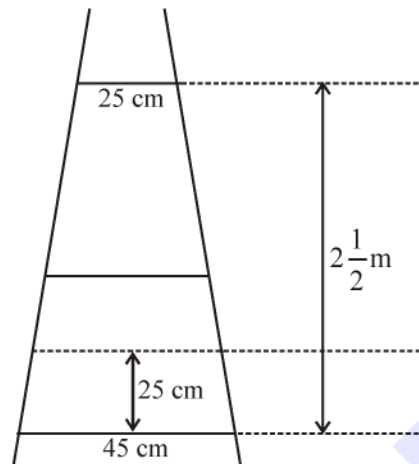

The rungs decrease uniformly in length from 45 cm at the bottom to 25 cm at the top. The top and the bottom rungs are $2\frac{1}{2}$ m apart.

- (i) What is the distance (in cm) between top and bottom rungs? (1)
- (ii) Find the number of the rungs. (1)
- (iii) What is the length of the wood required for all the rungs? (2)

OR

What is the length of second rung from top? (2)